



TUBE TOOLS



PORTABLE LINE BORING WELDING MACHINE



SHINGARETM
INDUSTRIES PVT LTD

MANUFACTURER & EXPORTER OF

Tube Cleaners, Tube Tools, Tube Expanders,
Bolting Tools, Impact Sockets,
Pipe Beveling Machines, Pipe Cold Cutting Machines,
High Pressure Water
Jet Cleaning Machines Tapping Machines

INTRODUCTION



TUBE TOOLS

Education is necessary but not a pre-requisite for success in life. Bhartiya Industries is the best example of this theory. **Mr. Suryakant Shingare** (HARIBHAI), the founder of the company is a non-matriculate technocrat with more than 10 years experience in flexible shaft manufacturing. He founded this company in 1989.



Basic Products:

Engineering products is our forte. We manufacture engineering products such as tube expander, tube cleaner, tube tools, hydraulic tube expansion, tube pulling, and pipe beveling machines. We also deal in manufacture of flexible shaft grinders, construction equipment, hydraulic torque wrench, impact socket, pneumatic tapping machines, and many more...

Brief History of the Company:



We were a small industry until 2003 engaged in production and supply of different types of flexible shafts for tube cleaning, brushes, flexible shaft grinder, and concrete vibrators. The year 2003 was a watershed year for the company.

Mr. Pradip Shingare, son of **Mr. Hari Shingare**, graduated from Mumbai University with a degree in Mechanical Engineering. He had great plans to take the company forward on the route to expansion. He ventured into export of the engineering products. By 2008, the company acquired the reputation as the largest exporter of tube cleaning machines and flexible shafts in India.

The year 2009 saw the expansion of the company into manufacture of products such as Tube expander, tube tools, and tube pulling machines. The company witnessed a record double-digit growth in this product range. In 2011, the company started developing a product range of pipe beveling machines. These machines are extremely popular in India as well as in the overseas market. The year 2013 witnessed the company foray into imports of different types of tools such as tapping tools, grinding tools, etc making us the leading player in India in these categories.

The year 2015 saw us entering into the sugar industry component with the manufacture of the Heavy Duty Sugar Dust Collector machine, FlexRepair40 machine.

In 2016, we added **SHINGARE INDUSTRIES PVT. LTD.** a new company in our group. We were awarded ISO 9001:2015 certification for strictly followed quality norms and processes.

Dedicated Staff:

We have a dedicated team of more than 40 people, many of whom are with us since the early days of the company. We have an excellent blend of youth, knowledge, and experience in our ranks.

Export oriented:

We export over 60% of our products to more than 55 countries all over the globe.

Expansion:

We feel the need to expand our business to enable us to serve the people of this country better. With this aim in mind, we established a new company in the name of SHINGARE INDUSTRIES PVT. LTD.

Our main motto of business is “Growth with Trust.”

Our mission is to innovate and create an import substitute products in India.

SILBWM-50 INTELLIGENT BORING AND WELDING MACHINE :

It is portable, the volume is ahead of the industry, and the processing & Welding diameter can be 300mm max. Besides, it has the ability of remote operation by remote controller.

POWERFUL PROCESSING CAPABILITY :

It is a combination of more than ten years of experience in hole repairing, including: shaft pin hole, hinge hole or ship link hole, steam turbine pair wheel link hole , Turning processing of pump valves, pipe inner holes and automatic welding repair of inner holes.

AUTOMATIC WELDING SYSTEM :

Automatic welding only needs to input the aperture to the controller to complete the automatic welding work. It also has the functions of skip welding and swing welding.

ULTRA-HIGH-STRENGTH BORING BAR:

It is made of 40Cr/42CrMo material. It has heat treatment processes such as overall high-frequency quenching, modulation, and surface chrome plating. It has high strength and brings a strong guarantee for cutting and finishing.

MACHINE PICTURE



PRODUCT ADVANTAGE

1. INTELLIGENT REPAIR WELDING

Enter the aperture, one-key repair welding, no need to manually adjust the speed, automatic matching

2. SMART SWING AND SKIP WELDING

Oval hole, semicircle welding, etc. Input the width to be welded, complete with one key.

3. POWERFUL BORING

The maximum single-side tooling amount can reach 8mm, and it can also boring double holes at the same time.

4. HIGH BORING PRECISION

The accuracy tolerance of the through hole is 0.02mm, and the ovality is 0.01mm.

5. SUPER POWER

3.1 KW servo motor, 220V/380V optional.

SPECIFICATION

Sr. No.	Model	SILBWM-50 line boring and welding machine
1	Boring Range	55-300mm
2	Size of Boring Bar	50x1600mm&50x400mm&50x300mm
3	Boring Spindle Speed	50-300RPM
4	Boring Capacity	The Maximum Boring Depth
		8mm on One Side
5	Surface Roughness	Ra3.2
6	Hole Roundness Error	≤0.02mm
7	Welding Range	40-300mm
8	Welding Capacity	Welding Rod Length
		800mm&300mm&240mm&200mm
9		Welding Thickness One Side
		4-5mm
10		Welding Wire Diameter
		0.8/1.0/1.2mm
11	Max Axial Travel	300mm (Can be customized, Maximum 1000mm)
12	Axial Feeding Speed	0-0.8m/min
13	Motor Power	3.1kw
14	Voltage & Frequency	220V, 60hz/380V, 50Hz

DUAL SYSTEM FOR SILBWM-50



Features :

- The powerful automatic protection function makes the SILBWM-50 have a longer service life, and it is easier to be maintenance-free.
- Boring and repair welding-boring and automatic inner circle repair welding only needs one revolution to complete the system switching, making the operation more convenient.
- Automatic inner circle repair welding system, remote control feed position adjustment, large and small aperture input, truly achieve controllable accuracy. The fan surface can be adjusted at will, and smart jump welding can be completed by one button.
- Automatic inner circle repair welding can be used for jump welding, sector welding, full circle welding, slot welding and other requirements.

MACHINE PACKING LIST

BORING ACCESSORIES					
1	Main Machine (1 Set)		9	Bearing Mounts (2 Pcs)	
2	Electrical Control Box (1 Set)		10	Hexagon Wrench (2 Pcs)	
3	Servo Motor 3.1kw (1 Set)		11	Feeding Assembly (1 Pcs)	
4	Feeding Motor (1 Set)		12	Tool Cutter (12+4 Pcs)	
				Tool Cutter (80+20 Pcs)	
5	Boring Bar 50x350mm (1 Set)		13	Anti-Vibration Frame (1 Set)	
6	50x350mm Boring Bar (1 Set)		14	Positioning Device (1 Set)	
7	50x400mm Boring Bar (1 Set)		15	Large Tool Cutter (160-300mm) (1 Set)	
8	50x1600mm Boring (1 Set)		16	Large Bearing Mount (160-300mm) (1 Set)	

LINE BORING MACHINE SILBWM-50



TUBE TOOLS

Welding Accessories

1	Welding Cable (1 Set)		5	200/240/300/800 mm Torch	
2	Remote Controller (2 Pcs)		6	Welding Nozzles (40+40 Pcs)	
3	Adapter (1 Set)		7	Universal Torch Head (1 Pcs)	
4	Protection Nozzle (10+10 Pcs)				

PLH50 MACHINE STRUCTURE

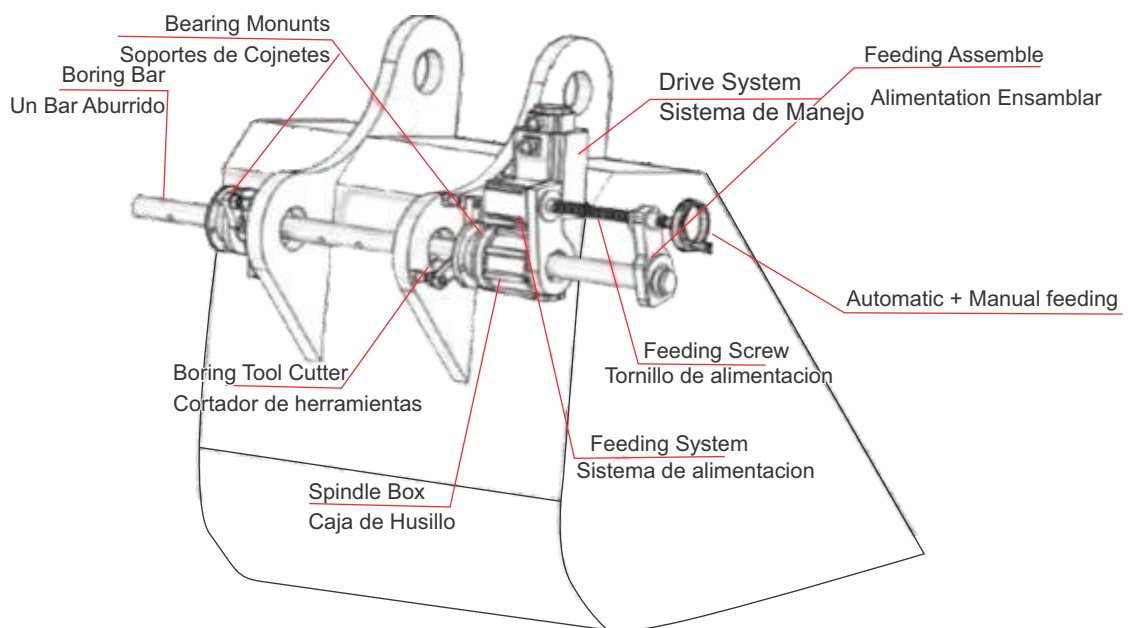

1. TECHNICAL SPECIFICATIONS OF SIPLBM-40

1.1 MACHINE PICTURES ONLY FOR YOUR REFERENCE

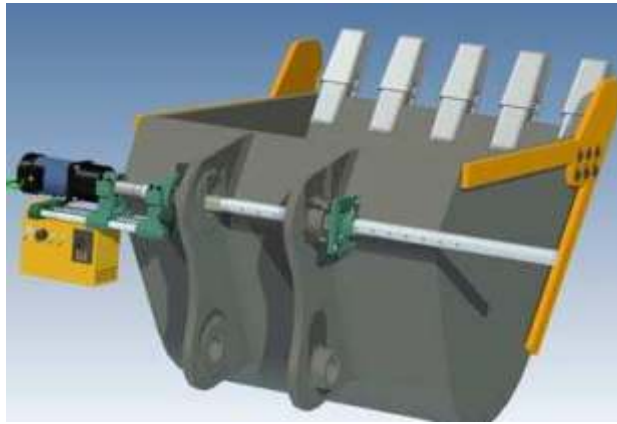









STRUCTURE FOR SIPLBM-40

1. Supporting seat A
2. Boring bar
3. Suppor
4. Rack ting seat B
5. DC motor
6. Emergency stop switch
7. Feeding turning button
8. Feeding speed governing button
9. Speed governing button for motor rotation
10. Alternate switch of motor steering

SPECIFICATIONS

NO.	ITEMS	UNIT	SIPLBM-40
1	Boring Bar Diameter	mm	40
2	Length of Boring Bar	mm	1500mm
3	Boring Spindle Speed	RPM	0-125 Suggested 50rpm when using HSS Tool
4	Max Axial Travel	mm	360
5	Axial Feeding Speed	mm/r	0-0.8
6	Motor Power	KW	1.5
7	Boring Diameter	mm	φ 45-φ180(Max 200)
8	The Maximum Boring Depth	mm	2mm on one side(φ 45-180)
			1mm on one side (φ 180-200)
9	Surface Roughness		Ra3.2
10	Machining Tolerance	mm	Less than 0.1
11	Voltage and Frequency	--	220V, 50hz, Single Phase

STANDARD ACCESSARIES ONLY FOR YOUR REFERENCE

Sr. No.	PICTURE	DETAILS	FEATURE
1		NAME: Main Body Qty: 1set	Machine adopts domestic DC motor, large torque, long life. Beautiful design enjoy tremendous popularity, English panel is easy for new users.
2		NAME: Bolts for Welding Qty: 8 pieces	Machine adopts domestic DC motor, large torque, long life. Beautiful design enjoy tremendous popularity, English panel is easy for new users.
3		NAME: Bearing mounts Qty: 2sets	Different size bearing mounts, this is for supporting the boring bar and for welding the bolts with construction parts.
4		NAME: Bolts for Welding Qty: 8 Pieces	2 pairs, (1 pair= 4 pieces) necessary for welding between constructions parts and bearing mounts, this part can be used many times.
5		NAME: Nylon Positioning Block Qty: 1set	Nylon positioning block, standard size with doesn't any environment any damage.
6		NAME: Tool Holder Qty: 3 pieces	Tool holder were provided for free, customer can prepare cutting tools 12x12x200mm in advance according to cutting request.
7		NAME: Cutting Tools Qty: 1 piece	One pieces cutting tools were provided for free, HSS cutting tools is the perfect tools for boring the hole, more pieces needed need extra charge, but we will provide factory price on this.
8		NAME: Tools & Spanner Qty: 1 Set	Common tools for portable line boring machine, Allen key and spanner are easy to tight and loose the nuts.
9		NAME: Remote Control Qty: 1Set	Remote control for controlling spindle speed direction; feed direction which is easy to use when machine installed with the workpiece.

LINE BORING MACHINE SIPLBM-200

Features :

1. Processing and repairing the rotation hole, reaming, pin-hole, installation an remain hole of structure member for kinds of machine.
2. The spindle adopts 220V motor with the feature of higher torque at lower speed.
3. There is no vibration for the axial movement and cutting process to ensure stable cutting.
4. Processing and repairing concentric interval hole of excavator and crane.
5. Processing porous one-time, ensuring porous in alignment.

SPECIFICATIONS

MODEL	SIZE
Min. boring dia.	45mm
Max. boring dia.	200mm
Boring bar	40 x 1500mm
Spindle speed	0 to 80rpm/min
Max. stroke	300mm (Standard)
Max. cutting depth	2mm (single side)
Motor power	1.5Kw, DC motor
Roughness of boring	Ra3.2
Roundness tolerance	≤0.02mm
Net. Weight	100kg



Features :

1. The boring bar adopt high-strength structural alloy steel, after more than once stress relieving, surface chrome-plating and polishing processing to ensure the high strength and not easy to deformation.
2. It can realize that installation of boring in horizontal or vertical, the function of end face milling can be optional.
3. Various supporting and fixed device can meet the demand of different working condition.
4. It has high working accuracy, the surface roughness up to Ra3.2.
5. Axial direction can be automatic feeding and equipped with more gear variable speed device to output most appropriate feed for rough or finish machining.
6. It has quick returning function, easy to operate.
7. Within the effective travel, the tool post can be installed anywhere.



OUR MACHINE ADVANTAGE COMPARED WITH SAME INDUSTRY

- By adopting 220V DC motor with characteristics of Low speed of revolution an high torque the machine can realize stable machining in superior performance.
- No vibration in axial travel and cutting process.
- Feeding and processing can realize unlimited speed control. Feeding process can be set according to requests, ad processing can automatically stop after reaching the limit switches.
- Boring bar adopted hig-strength alloy which with high hardness, high accuracy, high tenacity, good abrasion resistance, etc.
- Within the effective travel, the tool rest can be fixed at any position of boring bar.
- The boring bar can be disassembled separately to make installation convenient.
- Electric motor controller is equipped with dynamic delay brake program to avoid vibration in shutdown.
- The control cabinet is installed below the main engine to be beneficial to safety operation.
- The equipment also has extended functions on boring end face. Customers can select the function according to processing demands.

PORTABLE MANUAL LINE BORING MACHINE SIMLBM-40

MODEL	SIZE
Boring Bar Diameter	40 mm
Length Of Boring Bar	1000 mm
Suggested 50 RPM When Using	50 RPM when using HSS Tool
Max Axial Travel	250mm
Motor Power	1 HP
Boring Diameter	φ45-φ200mm
Voltage And Frequency	220V, 50hz, Single phase Or Three Phase 440V

MACHINE ACCESSORY:

- 1) Main Machine
- 2) 1x Boring Bar 1000 mm(Boring bar length can be customized according to customers requests).
- 3) 2x supporting seats
- 4) 1XBoring Tool 12x12x75 mm M 35 GRADE
- 5) TOOL SET(ALLEN KEY ,SPANNER)
- 6) OIL CAN



LINE BORING MACHINE SIPLBM-200

NO	MODEL	Qty	Pieces
1	Main Machine	1set	
2	Boring Bar Dia. 40x1500mm Length	1 Pcs	
3	Supporting Bolts	8 Pcs	
4	Boring Cutter	8 Pcs	
5	Locating Sleeve	4 Pcs	
6	Support Connecting Main Machine	4 Pcs	
7	End Support	1 Pcs	
8	Fastening Screw for Cutter	1 Pcs	
9	Tools	4 Pcs	

OUR MAJOR CLIENTS

Please see below our robust and valued client list that uses BHARTIYA products repeatedly. We take pride in our partnerships and the ability to grow with such amazing group of companies.



SHINGARE[™]
INDUSTRIES PVT LTD

SHINGARE INDUSTRIES PVT. LTD.
Formerly known as Bharatiya Industries

Manufacturer & Exporter of Tube Cleaners, Flexible Shafts, Tube Tools, Impact Sockets, Bolting Tools, Pipe Cold Cutting and Beveling Machines, Torque Tools, Grinding Tools, Tapping Tools, Hydraulic Torque Wrench, Electric Torque Wrench, Manual Torque Wrench & Torque Multiplier

Factory Add: A-48 B Osiya Mataji Compound, Village Kalher, Retibunder Road, Tal. Bhiwandi, Dist. Thane - 421302, Maharashtra.

Hade Off: A-104, 1st Floor, Eastern Business District (Magnet/Neptune Mall), L.B.S. Marg, Bhandup (west), Mumbai - 40078.

+91 77188 96512 | + 91 90290 05461 | bharatflex@yahoo.com | spradip@tubecleaner.co.in

www.shingare.com | www.tubecleaner.co.in