

# BOILER TUBE EXPANDER

## TYPE 'BV' NON PARALLEL EXPANSION TUBE EXPANDING AND BEADING IN SINGLE OPERATION FEATURES:

Tube O. D.  
1" - 3"

- USE: Type "BV" Expander for repair and erection of boiler having thin tube sheets. Its is approximate twice as fast during use than other conventional expanders. Use header Mandrel when expanders is to be used through a watering.

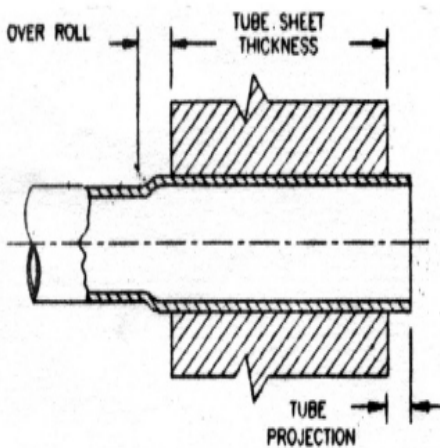

TUBE SIZE			EXPANSION RANGE *				EFFECTIVE ROLLING LENGTH		TUBE EXPANDER (WITH SHORT MANDREL) MODEL NO.	SPARE MANDREL			SPARE ROLLER SET
O.D. Inch	THK. GA	THK. inch	DIM. A mm	DIM. B inch	DIM. A mm	DIM. B inch	mm	inch		SHORT MANDREL NO.	HEADER MANDREL NO.	MANDREL SQ.	
1	10 - 13 (.134 - .095)		(17.3 - 23.7)	(.681 - .937)	84.20	(3.5/16)	BV - 1	BVSM - 1	BVHM - 1	1/2	BVR - 1		
1.1/4	10 - 13 (.134 - .095)		(23.8 - 30.6)	(.940 - 1.206)	84.20	(3.5/16)	BV - 2	BVSM - 2	BVHM - 2	1/2	BVR - 2		
1.1/2	10 - 13 (.134 - .095)		(29.3 - 37.3)	(1.156 - 1.469)	101.20	(4.000)	BV - 3	BVSM - 3	BVHM - 3	1/2	BVR - 3		
2	10 - 13 (.134 - .095)		(42.3 - 49.7)	(1.665 - 1.960)	101.20	(4.000)	BV - 4	BVSM - 4	BVHM - 4	3/4	BVR - 4		
2.1/2	10 - 13 (.134 - .095)		(54.5 - 62.7)	(2.145 - 2.469)	101.20	(4.000)	BV - 5	BVSM - 5	BVHM - 5	3/4	BVR - 5		
3	10 - 13 (.134 - .095)		(68.2 - 76.6)	(2.687 - 3.015)	101.20	(4.000)	BV - 6	BVSM - 6	BVHM - 6	1	BVR - 6		

NOTE : Other sizes available on request